



# GM Small Block V8 LS Engine Family Chevy Gen III

## PERFORMANCE ENGINE SEALING

### Cylinder Head Gaskets

Part Number	Bore	Thickness	Volume	Description
<b>Steel Core Laminate with pre-flattened wire ring</b>				
1041	4.135"	.041"	9.4cc	2 req. LS1/LS6
<b>PermaTorque® MLS</b>				
1160L-041*	3.945"	.041"	8.2cc	Left-hand. LS1/LS6
1160L-053*	3.945"	.053"	10.6cc	Left-hand. LS1/LS6
1160R-041*	3.945"	.041"	8.2cc	Right-hand. LS1/LS6
1160R-053*	3.945"	.053"	10.6cc	Right-hand. LS1/LS6
1161L-041*	4.100"	.041"	8.9cc	Left-hand. LS1/LS6
1161L-053*	4.100"	.053"	11.5cc	Left-hand. LS1/LS6
1161R-041*	4.100"	.041"	8.9cc	Right-hand. LS1/LS6
1161R-053*	4.100"	.053"	11.5cc	Right-hand. LS1/LS6
1162L-041*	4.175"	.041"	9.2cc	Left-hand. LS1/LS6
1162L-053*	4.175"	.053"	11.9cc	Left-hand. LS1/LS6
1162R-041*	4.175"	.041"	9.2cc	Right-hand. LS1/LS6
1162R-053*	4.175"	.053"	11.9cc	Right-hand. LS1/LS6
1185-041*	4.175"	.041"	9.2cc	World Products Warhawk, 2 req.
1185-053*	4.175"	.053"	11.9cc	World Products Warhawk, 2 req.
26472L-041*	4.100"	.041"	8.9cc	Left-Hand. GM LSX
26472L-053*	4.100"	.053"	11.5cc	Left-Hand. GM LSX
26472R-041*	4.100"	.041"	8.9cc	Right-Hand. GM LSX
26472R-053*	4.100"	.053"	11.5cc	Right-Hand. GM LSX
26473L-041*	4.200"	.041"	9.3cc	Left-Hand. GM LSX
26473L-053*	4.200"	.053"	12.0cc	Left-Hand. GM LSX
26473R-041*	4.200"	.041"	9.3cc	Right-Hand. GM LSX
26473R-053*	4.200"	.053"	12.0cc	Right-Hand. GM LSX
26474-041*	4.270"	.041"	9.6cc	2 req. GM LSX
26474-053*	4.270"	.053"	12.4cc	2 req. GM LSX
26494L-041*	4.100"	.041"	8.9cc	RHS Aluminum Block
26494R-041*	4.100"	.041"	8.9cc	RHS Aluminum Block
26495L-041*	4.165"	.041"	9.2cc	RHS Aluminum Block
26495R-041*	4.165"	.041"	9.2cc	RHS Aluminum Block
26496L-041*	4.200"	.041"	9.3cc	RHS Aluminum Block
26496R-041*	4.200"	.041"	9.3cc	RHS Aluminum Block

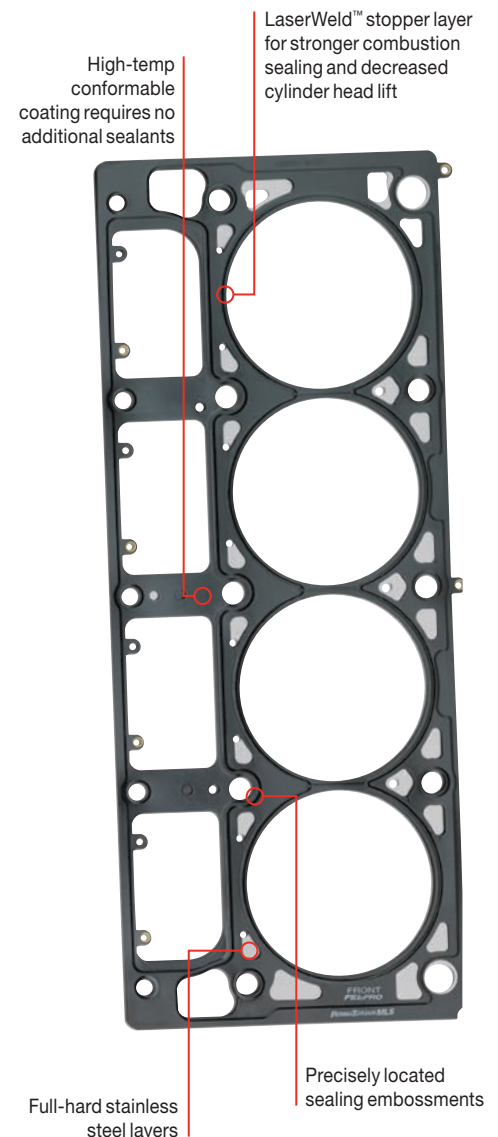

\*Suitable for Marine Applications



# GM Small Block V8 LS Engine Family Chevy Gen III

## PERFORMANCE ENGINE SEALING

### Intake Manifold Gaskets

Part Number	Dimensions	Description
1208-2	1.45" x 2.45" x .045" Thick	Composite with Printoseal® LS7
1208-3	1.45" x 2.45" x .060" Thick	Composite with Printoseal® LS7
1222-2	1.35" x 2.70" x .045" Thick	Composite with Printoseal® L92
1222-3	1.35" x 2.70" x .060" Thick	Composite with Printoseal® L92
1312-1	1.19" x 3.34" x .030" Thick	Composite with coating, LS1/LS6
1312-2	1.19" x 3.34" x .045" Thick	Composite with coating and Printoseal® LS1/LS6
1312-3	1.19" x 3.34" x .060" Thick	Composite with coating and Printoseal® LS1/LS6
1312-4	1.19" x 3.34" x .090" Thick	Composite with coating and Printoseal® LS1/LS6
1312-5	1.19" x 3.34" x .120" Thick	Composite with coating, LS1/LS6



#### Intake Manifold

Fel-Pro® Performance intake manifold gaskets for LS engines feature a composite material that resists coolant, gasoline, alcohol and oil. As needed, Printoseal® elastomeric sealing beads are used to provide the extra sealing strength needed around the port. These gaskets are designed and optimized for true race applications.



### Exhaust Header Gaskets

Part Number	Dimensions	Description
1438	1.75" x 1.55"	Perforated steel core with anti-stick coating, Stock exhaust ports, LS1/LS6
1440	1.90" Dia.	Perforated steel core with anti-stick coating, Large race ports, LS1/LS6

#### Exhaust Header

Fel-Pro® Performance exhaust header gaskets consist of a high-density fiber facing material attached to both sides of a perforated steel core. This technology resists blowout and burnout from high-temperature exhaust and is far stronger than the basic paper gaskets sold by competitors. This design also provides a durable gasket that can seal slightly warped surfaces. The high-density fiber material has excellent torque retention qualities as well.

Since the headers run hotter than the cylinder head, the two expand and contract at different rates. This causes a scrubbing motion which can eventually damage the gasket and cause it to fail. An anti-stick coating on these gaskets permits motion without damaging the gasket. In addition, this coating makes it easier to remove the gasket for future engine service.

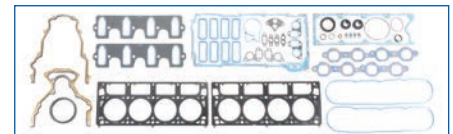

#### Full Set

Fel-Pro® Performance Full Sets include the latest race-proven engine sealing technologies, including Fel-Pro PermaTorque®MLS multi-layer-steel head gaskets, rigid-core molded-rubber valve cover and one-piece oil pan gaskets, steel-core intake manifold gaskets, and high-temperature crankshaft seals.

These premium Fel-Pro Full Sets apply the latest and best application-specific technologies to each engine platform and gasket, then pull the gaskets together into a single gasket kit.

### Full Set

Part Number	Dimensions	Description
2810**	3.945" Bore	Premium engine sealing set. Set contains MLS cylinder head gaskets, molded rubber valve cover and oil pan gaskets, intake manifold gaskets, plus gaskets and seals required to reassemble engine. LS1/LS6
2817**	4.100" Bore	Premium engine sealing set. Set contains MLS cylinder head gaskets, molded rubber valve cover and oil pan gaskets, intake manifold gaskets, plus gaskets and seals required to reassemble engine. LS1/LS6

\*\*For applications not covered, use individual components

You can quickly and easily locate the Fel-Pro® Performance gaskets you need via the online lookup available 24/7 at [www.fme-cat.com](http://www.fme-cat.com). In addition to offering comprehensive, up-to-date Fel-Pro Performance gaskets coverage, this site also includes Speed-Pro® Performance Engine Parts and Champion® Spark Plugs.

The complete Fel-Pro catalog can also be accessed and downloaded from the site (follow the "Technical Info," "Digital Catalogs" and "Performance" tabs).

**24/7 online parts lookup at [www.fme-cat.com](http://www.fme-cat.com)**